

BREATHER DRAIN ADAPTOR

Ex e, Ex ta, IP65, IP66

for Hazardous Area Installations

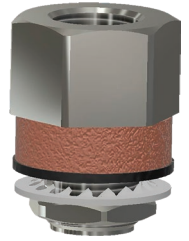

Features and Benefits

- Precision machined from high quality brass (Marine Grade Electroless Nickel Plated™)
- Supplied with a serrated washer and locknut for use when fitted to unthreaded entries.
- Drains water from equipment susceptible to moisture collection, using the same entry hole as a cable entry device.
- Enables equipment to breathe whilst maintaining protection levels.

Technical Data

Type:	Breather / Drain Adaptor for Ex e applications.
Material:	Body and locknut: Brass (Marine Grade Electroless Nickel Plated™) Serrated washer: Stainless steel. Sinter: Bronze (electroless nickel plated) or stainless steel. Sealing gasket: HDPE, Nylon 66 or PTFE
Note:	The installer should ensure that the materials are suitable for the installation environment.

Standards and Certifications

Equipment Protection Level:	IECEX: Ex eb I Mb / Ex eb IIC Gb, Ex ta IIIC Da ATEX/UKEX: Ex I M2 Ex eb I Mb / Ex II 2G 1D Ex eb IIC Gb, Ec tb IIIC Db TR CU: Ex I Ex e IIC Gb X, Ex tb IIIC Db X	
Service Temperature	The service temperature ranges are determined by the sealing gasket material and are as follows:- HDPE gasket: -60°C to +95°C Nylon gasket: -60°C to +100°C PTFE gasket: -60°C to +160°C	
Conformance:	Standard:	Certificate:
IECEX	IEC 60079 Part 0, 1, 7, 31	IECEX CML 16.0021X
ATEX	EN 60079 Part 0, 1, 7, 31	CML 16ATEX1029X
UKEX	BS EN 60079 Part 0, 1, 7, 31	CML 21UKEX1018X
TR CU (Russia)	ГОСТ 31610-0, 15, ГОСТ IEC 60079-1 ГОСТ P MЭК 60079-7, 31	EAЭC RU C-ZA.HA91.B.00244/21
SANS	SANS/IEC 60079 Part 0, 1, 7, 31, IEC 60529	MASC MS/16-1175X
IP66	IEC 60529	IECEX CML 16.0021X
Deluge Protection	DTS-01	CML 14CA370-2
Marine ABS	IEC 60079 Part 0, 1, 7, 15, 31, IEC 60529	ABS 20-1952706-1-PDA
DNV-GL	IEC 60079 Part 0, 1, 7, IEC 60529	DNV-GL TAE0000010



Conditions for Safe Use

- To operate as a draining device the breather/drain adaptor must be installed at the bottom of the equipment.
- The service temperature ranges shall not be exceeded.

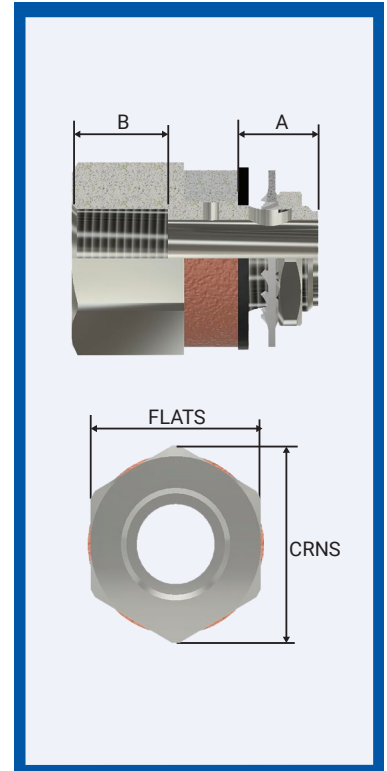

Product Code	Male Thread		Female Thread		Hexagonal Detail		*Install. Torque Value Nm
	Thread 'A'	Min. Length 'A'	Female Thread	Min. Length 'B'	Max 'Flats'	Max 'Crns'	
BAM020M020E	M20 x 1.5	15	M20 x 1.5	18.0	32.0	36.0	21.0
BAM020M025E	M20 x 1.5	15	M25 x 1.5	18.0	32.0	36.0	21.0
BAM025M020E	M25 x 1.5	15	M20 x 1.5	18.0	38.0	42.8	30.0
BAM025M025E	M25 x 1.5	15	M25 x 1.5	18.0	38.0	42.8	30.0
BAM025M032E	M25 x 1.5	15	M32 x 1.5	18.0	38.0	42.8	30.0
BAM032M020E	M32 x 1.5	15	M20 x 1.5	18.0	42.0	47.3	42.0
BAM032M025E	M32 x 1.5	15	M25 x 1.5	18.0	45.0	50.6	42.0
BAM032M032E	M32 x 1.5	15	M32 x 1.5	18.0	45.0	50.6	42.0
BAM032M040E	M32 x 1.5	15	M40 x 1.5	18.0	45.0	50.6	42.0
BAM020N012E	M20 x 1.5	15	½ NPT	18.0	32.0	36.0	21.0
BAM020N034E	M20 x 1.5	15	¾ NPT	18.0	32.0	36.0	21.0
BAM025N012E	M25 x 1.5	15	½ NPT	18.0	38.0	42.8	30.0
BAM025N034E	M25 x 1.5	15	¾ NPT	18.0	38.0	42.8	30.0
BAM025N001E	M25 x 1.5	15	1 NPT	18.0	38.0	42.8	30.0
BAM032N012E	M32 x 1.5	15	½ NPT	18.0	42.0	47.3	42.0
BAM032N034E	M32 x 1.5	15	¾ NPT	18.0	45.0	50.6	42.0
BAM032N001E	M32 x 1.5	15	1 NPT	18.0	45.0	50.6	42.0
BAM032N114E	M32 x 1.5	15	1¼ NPT	18.0	45.0	50.6	42.0
BAN012M020E	½ NPT	15	M20 x 1.5	18.0	32.0	36.0	21.0
BAN012M025E	½ NPT	15	M25 x 1.5	18.0	32.0	36.0	21.0
BAN034M020E	¾ NPT	15	M20 x 1.5	18.0	38.0	42.8	30.0
BAN034M025E	¾ NPT	15	M25 x 1.5	18.0	38.0	42.8	30.0
BAN034M032E	¾ NPT	15	M32 x 1.5	18.0	38.0	42.8	30.0
BAN001M020E	1 NPT	19	M20 x 1.5	18.0	42.0	47.3	42.0
BAN001M025E	1 NPT	19	M25 x 1.5	18.0	45.0	50.6	42.0
BAN001M032E	1 NPT	19	M32 x 1.5	18.0	45.0	50.6	42.0
BAM001M040E	1 NPT	19	M40 x 1.5	18.0	45.0	50.6	42.0
BAN012N012E	½ NPT	15	½ NPT	18.0	32.0	36.0	Wrench tight
BAN012N034E	½ NPT	15	¾ NPT	18.0	32.0	36.0	Wrench tight
BAN034N012E	¾ NPT	15	½ NPT	18.0	38.0	42.8	Wrench tight
BAN034N034E	¾ NPT	15	¾ NPT	18.0	38.0	42.8	Wrench tight
BAN034N001E	¾ NPT	15	1 NPT	18.0	38.0	42.8	Wrench tight
BAN001N012E	1 NPT	19	½ NPT	18.0	42.0	47.3	Wrench tight
BAN001N034E	1 NPT	19	¾ NPT	18.0	45.0	50.6	Wrench tight
BAN001N001E	1 NPT	19	1 NPT	18.0	45.0	50.6	Wrench tight
BAN001N114E	1 NPT	19	1¼ NPT	18.0	45.0	50.6	Wrench tight

All dimensions except NPT are in mm. The tightening torques shown apply to the metric threads. NPT threads are tightened 'wrench tight'.

CCG reserves the right to make alterations to the technical data, dimensions, designs and products available without notice. The illustrations cannot be considered binding. Please contact CCG for assistance. BREATH-AD161122

BREATHER DRAIN ADAPTOR

1. Tighten the breather / drain adaptor into the equipment using the torque specified in the table above.

2. If the breather / drain adaptor is to be used as a drain then it must be fitted to the bottom of the equipment.

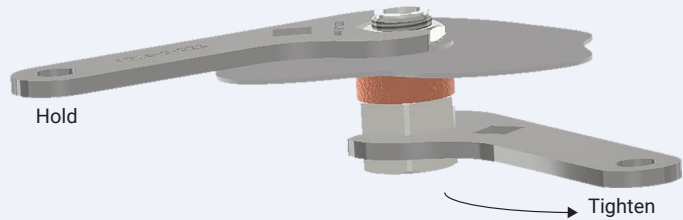

3. The serrated washer and locknut are only needed if the breather / drain adaptor is fitted to a clearance hole. They must be removed if the breather / drain adaptor is fitted to a threaded entry.

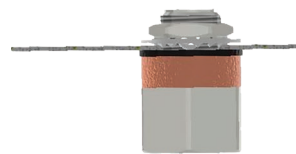

Breather/Drain Adaptor fitted to a clearance hole

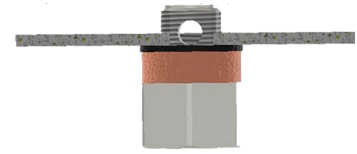

Breather/Drain Adaptor fitted to a thread entry.
(Serrated washer and locknut not required)

4. Hold the body of the breather / drain adaptor with a spanner when tightening a cable gland into the female thread.

