



FIXED T ADAPTOR

Ex db, Ex eb, Ex ta, IP65/66/68

for General Industrial and Hazardous Area Installations

Features and Benefits

- Allows two cable glands to be fitted to a single cable entry.
- Precision manufactured from high quality brass (Marine Grade Electroless Nickel Plated™)
- Supplied with a sealing gasket as standard. (Parallel male threads only.)
- Available in Metric BSPP, BSPT, ET and NPT thread forms.



Technical Data

Type:	Fixed T Adaptor
Material: Body:	Brass (Marine Grade Electroless Nickel Plated™)
Sealing gasket:	Standard HDPE / Nylon or Extreme Temp. PTFE
Note:	The installer should ensure that the materials are suitable for the installation environment.

Standards and Certifications

Equipment Protection Levels:	IECEX/INMETRO: Ex db I Mb / Ex eb I Mb, Ex db IIC Gb / Ex eb IIC Gb / Ex ta IIC Da ATEX/UKEX: I M2 Ex db I Mb / Ex eb I Mb, II 2 G, 1 D Ex db IIC Gb / Ex eb IIC Gb / Ex ta IIC Da
------------------------------	---

Operating temperature range:	-60°C to +95°C / 100°C (HDPE / Nylon sealing gasket) -60°C to 160°C (PTFE sealing gasket), -60°C to 100°C (thread grease)
------------------------------	--

Conformance:	Standard:	Certificate:
IECEX	IEC 60079 Part 0, 1, 7, 31	IECEX TSA 23.0023U
ATEX	EN 60079 Part 0, 1, 7, 31	CML 16ATEX1137U
UKEX	BS EN 60079 Part 0, 1, 7, 31	CML 21UKEX1012U
INMETRO (Brazil)	ABNT NBR IEC 60079, 0, 1, 7, 31	TÜV 16.1856U
SANS	SANS/IEC 60079 Part 0, 1, 7, 31	MASC MS/23-9594X
IP66/68 - Parallel	IEC 60529	CML 15Y728
IP65	IEC 60529	
IP68 - Tapered and approved grease	IEC 60529	IECEX TSA 23.0023U
Deluge Protection	DTS-01	CML 14CA370-2
Marine ABS	IEC 60079 Part 0, 1, 7, 15, 31, IEC 60529	ABS 20-SG1952706-1 PDA

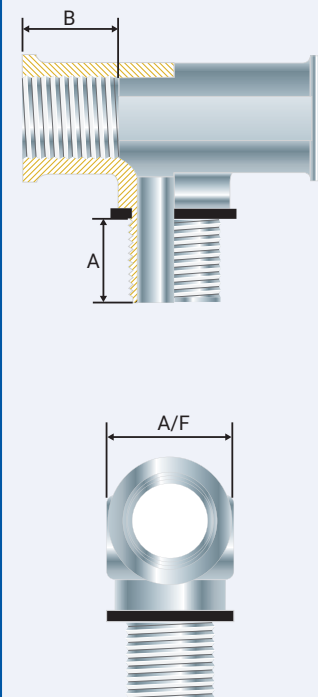

Conditions for Safe Use

- The service temperature range of -60°C to +95°C / 100°C / 160°C (HDPE / Nylon / PTFE sealing gaskets) -60°C to 100°C (thread grease) shall not be exceeded.
- All adaptors are rated IP65 for any sealing arrangement. If an IP rating of IP66/67/68 is required then the supplied sealing gasket shall be used. IP66/67/68 can also be achieved on threaded entries using an approved grease.

Product Code	Male Thread		Female Thread		Spanner Size A/F	Installation Torque Nm
	Type	Minimum Length 'A'	Type	Minimum Length 'A'		
FTM020M20E	M20x1.5	17.0	M20x1.5	16.0	27	21.0
FTM025M25E	M25x1.5	17.0	M25x1.5	16.0	35	30.0
FTM032M32E	M32x1.5	17.0	M32x1.5	16.0	40	42.0
FTM020N012E	M20x1.5	17.0	½" NPT	16.0	27	21.0
FTM025N034E	M25x1.5	17.0	¾" NPT	16.0	35	30.0
FTM032N001E	M32x1.5	17.0	1" NPT	18.0	40	42.0
FTN012M20E	½" NPT	17.0	M20x1.5	16.0	27	'wrench tight'
FTN034M25E	¾" NPT	17.0	M25x1.5	16.0	35	'wrench tight'
FTN001M32E	1" NPT	17.0	M32x1.5	16.0	40	'wrench tight'
FTN012N012E	½" NPT	17.0	½" NPT	16.0	27	'wrench tight'
FTN034N034E	¾" NPT	17.0	¾" NPT	16.0	35	'wrench tight'
FTN001N001E	1" NPT	17.0	1" NPT	18.0	40	'wrench tight'

All dimensions except NPT are in mm. For other thread types, contact CCG.

Note:

1. The female thread may be the size shown in the table or any size smaller.
2. The two female threads can be different types / sizes. For example FTN001M32N034E would have a 1" NPT male thread, one M32 female thread and one ¾" NPT female thread.

FIXED T ADAPTOR

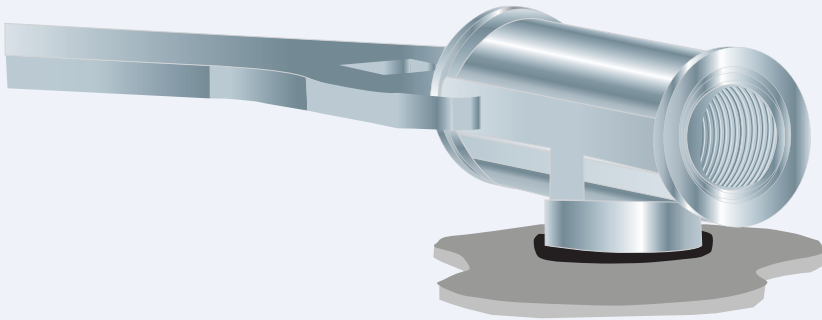

1. Ensure that the threaded entry on the equipment has a flat surface to engage the sealing gasket. Tighten the T Adaptor, complete with sealing gasket, into the equipment using a spanner until it is fully secured, noting the maximum torque figures in the table overleaf.

If the gland has NPT entry threads fitted to a threaded entry then IP68 (2m) can be achieved by applying one of the following tested and approved grease types to the thread:- Renolit Lubrene CA700 or LX220 EP2, Renolit LC-WP2 or Moly LX2, or Dow Corning 4 Electrical Compound.

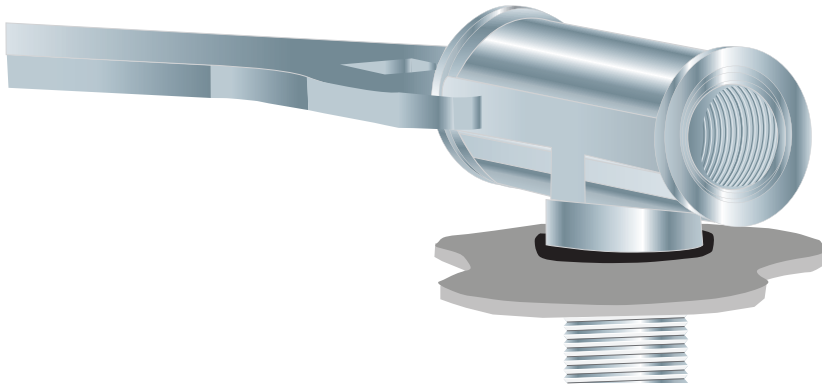

2. If fitting to a clearance hole, secure the T Adaptor using a locknut. (Use a serrated washer and locknut in high vibration areas.)

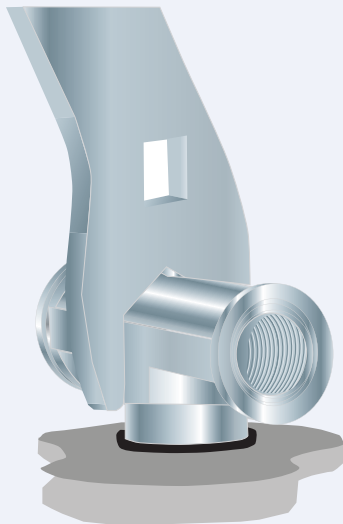

3. Ensure the T Adaptor is securely positioned and hold the adaptor flats using a CCG Spanner whilst fitting cable glands to the female threads.