

E1W VS

CAPTIVE COMPONENT GLAND®

for SWA, Copper Tape or Lead Sheathed Cable



Features and Benefits

- For indoor and outdoor use.
- Two-part handling, no loose parts. Freely rotating captive cone and inspectible cone ring providing an armour clamp and earth bond without twisting the armour wires.
- Patented disconnect system that allows inspection of armour clamp and inner seal after assembly.
- Provides 360° earthing to copper tape or lead sheath.
- Factory fitted with a specially formulated elastomeric seal for Built-in Safety™, seals on the inner and outer sheath of the cable.
- Precision manufactured from high-quality brass (Marine Grade Electroless Nickel Plated™) available in Aluminium or Stainless Steel 316/316L on request.
- Supplied with a thread-sealing gasket (parallel threads only).



Technical Data

Type:	E1W VS
Gland Material:	Brass (Nickel Plated), BS 2874, EN 12164, Aluminium ASTM BS221, Stainless Steel 316/316L
Seal Material:	Thermoset Elastomer or Silicone on request
Cable Type:	Steel Wire Armour, Copper Tape or Lead Sheathed
Armour Clamping:	Rotating Captive Cone and Inspectible Cone Ring
Sealing Area:	Inner Sheath and Outer Sheath
Optional Accessories:	Adaptor, Reducer, Earth Tag, Locknut, Serrated Washer and Shroud

Standards and Certifications

Mechanical Properties:	Impact Category 8 Anchorage Type D	
Electrical Properties:	Category A (no earth tag) Category B (with earth tag)	
Continuous Operating Temp:	-65°C to +120°C	
Conformance:	Standard:	Certification:
Design Standards	BS 6121:Part 1 EN 50262 IEC/BS EN 62444 SANS 62444 SANS 1213 IEC 60529	CML 14CA364 CML 14CA364 CML 14CA364 MASC 22-9012 MASC 26-9013, SANS 2109/4596 CML 15Y728, MASC 22-9015
IP66/68 100m - Parallel	IEC 60529	
IP65 - Tapered	IEC 60529	
Marine ABS	IEC 60529, IEC 62444	25-0167207-PDA
DNV	IEC 60529, BS 6121, IEC 62444	TAE000000Z
EMC Compatible	EN 55011, A1, EN 55022	SGS EMC305079/1
London Underground Approval	BS EN 62444	LU 3043

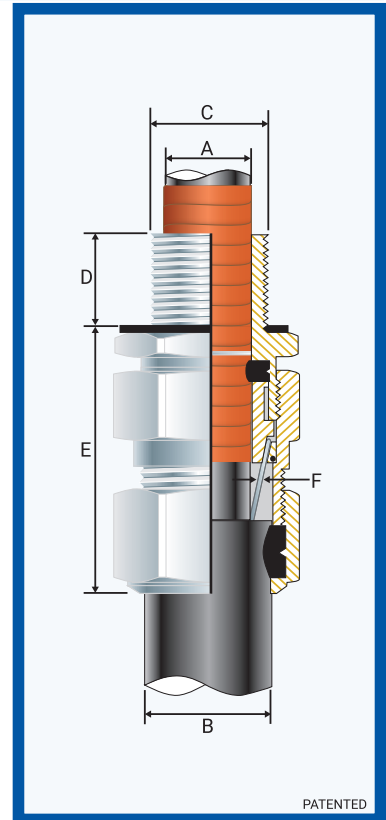

Installation Standards

- AS/NZS 3000
- BS 7671
- IEC 60364-5-54
- BS 6121-5
- BS 7430
- SANS 0142

Product Code	Gland Size Reference	Metric Entry Thread		NPT Entry Thread		Cable Detail				Max Length 'E'	Armour Dia		Hexagonal Detail		Install Torque Value Nm
		'C'	Min 'D'	'C'	Min 'D'	Min 'A'	Max 'A'	Min 'B'	Max 'B'		Min 'F'	Max 'F'	Max 'Flats'	Max 'Crns'	
051800-16-VS	00-16ss	M16x1.5	10	-	-	3.0	8.5	8.0	13.5	52.0	0.90	0.90	♦ 24.0	♦ 27.0	35.0
051800-VS	00-20ss	M20x1.5	10	½	15	3.0	8.5	8.0	13.5	52.0	0.90	0.90	♦ 24.0	♦ 27.0	35.0
0518-0-VS	0-20s	M20x1.5	10	½	15	7.0	12.0	11.5	16.0	52.0	0.90	1.25	♦ 24.0	♦ 27.0	35.0
051801-VS	1-20	M20x1.5	10	½/¾	15	11.0	15.0	14.5	20.5	56.0	0.90	1.25	27.0	30.0	35.0
051822-VS	2s-25s	M25x1.5	10	¾/1	15/19	11.0	17.5	16.0	24.5	65.0	1.25	1.60	35.0	39.0	50.0
051802-VS	2-25	M25x1.5	10	¾/1	15/19	14.0	20.0	20.5	26.5	65.0	1.25	1.60	35.0	39.0	50.0
051833-VS	3s-32s	M32x1.5	10	1/1¼	19	15.0	22.0	23.0	30.5	65.0	1.60	2.00	42.0	47.0	70.0
051803-VS	3-32	M32x1.5	10	1/1¼	19	19.0	26.5	26.5	33.5	65.0	1.60	2.00	42.0	47.0	70.0
051844-VS	4s-40s	M40x1.5	15	1¼/1½	19/21	22.0	31.5	30.0	39.5	80.0	1.60	2.00	52.0	59.0	90.0
051804-VS	4-40	M40x1.5	15	1¼/1½	19/21	26.0	34.0	33.0	42.5	80.0	1.60	2.00	52.0	59.0	90.0
051855-VS	5s-50s	M50x1.5	15	1½/2	21	29.0	38.0	34.0	47.5	95.0	2.00	2.50	65.0	73.0	100.0
051805-VS	5-50	M50x1.5	15	1½/2	21	34.0	44.5	42.5	52.5	95.0	2.00	2.50	65.0	73.0	100.0
051866-VS	6s-63s	M63x1.5	15	2/2½	30	38.0	50.0	45.5	60.5	116.0	2.00	2.50	80.0	90.0	120.0
051806-VS	6-63	M63x1.5	15	2/2½	30	44.0	56.5	52.5	65.5	116.0	2.00	2.50	80.0	90.0	120.0
051877-VS	7s-75s	M75x1.5	15	2½/3	32	50.0	62.0	57.0	72.5	127.0	2.50	3.15	96.0	102.0	120.0
051807-VS	7-75	M75x1.5	15	2½/3	32	56.0	67.5	65.5	78.0	127.0	2.50	3.15	96.0	102.0	120.0
051808-VS	8-80	M80x2.0	20	3	32	68.0	74.0	78.0	82.0	120.0	2.50	3.15	96.0	102.0	120.0
051899-VS	9s-90s	M90x2.0	20	3/3½	32/33	66.0	75.0	73.0	86.5	142.0	3.00	3.50	111.0	125.0	120.0
051809-VS	9-90	M90x2.0	20	3/3½	32/33	74.0	81.5	82.0	91.0	142.0	3.00	3.50	111.0	125.0	120.0
051810-VS	10-100	M100x2.0	20	3½/4	33/34	81.0	91.0	90.0	100.0	142.0	3.00	3.50	125.0	141.0	120.0
051811-VS	11-110	M110x2.0	20	4	34	86.0	98.0	100.0	114.0	142.0	3.00	4.00	135.0	152.0	120.0
051812-VS	12-120	M120x2.0	20	-	-	96.0	103.0	103.0	118.0	142.0	3.00	4.00	140.0	158.0	120.0
051813-VS	13-130	M130x2.0	20	-	-	100.0	115.0	113.0	124.0	165.0	3.00	4.00	146.0	164.0	120.0

All dimensions except NPT are in mm.

* When manufactured in Aluminium, Hex will be 27 Across Flats and 30 Across Corners.

CCG reserves the right to make alterations to the technical data, dimensions, designs and products available without notice. The illustrations cannot be considered binding. Please contact CCG for assistance. E1WVS-IN010626E

E1W VS CAPTIVE COMPONENT GLAND®

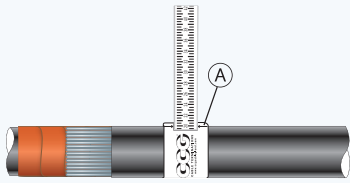

1. For accurate sizing, use a CCG Dimension Tape (A) on the inner and outer cable sheath.

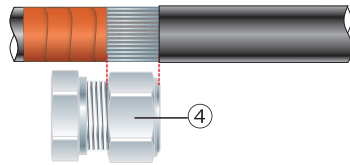

2. Cut the PVC sheath to expose the copper tape or lead sheath to the length of the inner (4).

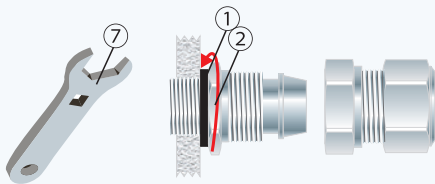

3. To maintain IP66/68, ensure the gasket (1) is in place. Screw the inner (2) into the apparatus. Tighten the inner (2), to the installation torque using a CCG Spanner (7).

Alternative installation through an unthreaded entry.

If the apparatus is untapped use a locknut.

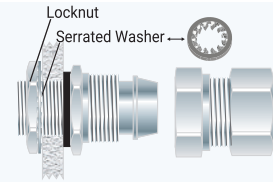

If the gland has NPT entry threads fitted to a threaded entry then IP68 (2m) can be achieved by applying one of the following tested and approved grease types to the thread:- Renolit Lubrene CA700 or LX220 EP2, Renolit LC-WP2 or Moly LX2, or Dow Corning 4 Electrical Compound.

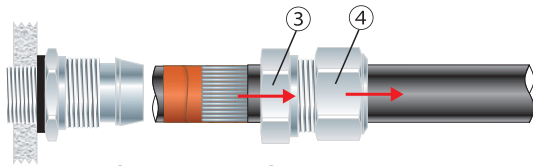

4. Pass the outer nut (4) and the body (3) over the cable.

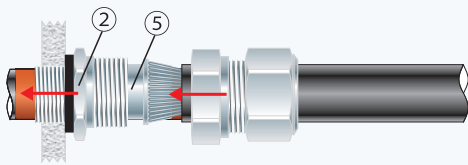

5. Pass cable end through the inner (2) ensure the copper tape does not unravel. Splay the armour wires over the cone (5).

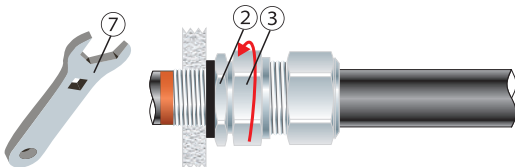

6. Tighten the body (3) onto the inner (2) until hand tight, then tighten with a CCG Spanner (7) with ¼ turn to lock the armour between the cone (5) and the cone ring (6).

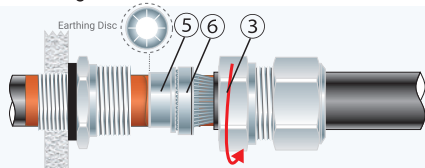

7. Unscrew the body (3). Check that the armour has locked between the cone (5) and the cone ring (6). (O-Ring on the cone (5) and cone ring (6) are sacrificial). Check the copper tape or lead sheath has passed through and makes 360° contact with the earthing disc.

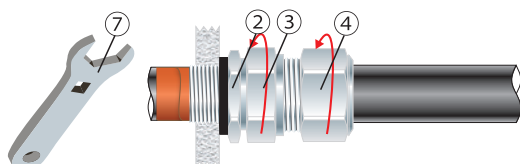

8. Tighten the body (3) onto the inner (2) to the installation torque using a CCG Spanner (7). Tighten the outer nut (4) to produce a moisture proof seal by turning until the seal makes contact with the outer sheath of cable and then turn one full turn.