

# A2 LSOH EMC

## COMPRESSION GLAND

### for Unarmoured Fire Rated Braided Cable



#### Features and Benefits

- For indoor and outdoor use.
- Seals the cable sheath to IP65/66/68.
- Provides 360° earthing.
- Precision manufactured from high-quality Brass (nickel-plated), available in Aluminium or Stainless Steel 316/316L on request.
- Silicon seals are fire-retardant, low-smoke smoke zero-halogen and suitable for extreme temperatures.
- Complete with fire retardant, low smoke zero halogen, extreme temperature thread sealing gasket.
- Complete with a heavy-duty locknut.



#### Technical Data

Type:	A2 LSOH EMC
Gland Material:	Brass (Nickel Plated) BS 2874, EN 12164, Aluminium ASTM BS221, Stainless Steel 316/316L
Seal Material:	LSOH Silicon
Cable Type:	Unarmoured Fire Rated Braided
Sealing Area:	Outer Sheath
Optional Accessories:	Adaptor, Reducer, Earth Tag, Locknut, Serrated Washer and Shroud

#### Standards and Certifications

Mechanical Properties:	Impact Category 8 Anchorage Type B
Continuous Operating Temp:	-65°C to +175°C
Conformance:	Standard: Certificate:
Design Standards	BS 6121:Part 1 CML 14CA364 EN 50262 CML 14CA364 IEC/BS EN 62444 CML 14CA364 SANS 62444 MASC 22-9012 SANS 1213 MASC 26-9013, SANS 2109/4596
IP66/68 100m - Parallel	IEC 60529 CML 15Y728, MASC 11-263
IP65 - Tapered	IEC 60529
Marine ABS	IEC 62444 25-0167207-PDA
DNV	IEC 60529, BS 6121, IEC 62444 TAE000000Z
Halogen Free	NAC259 TDWR 14-04-13
Flame Retardant	ASTM D 2863-09, ISO 4589-2 TDWR 14-04-13
Low Smoke	BS EN61034-2, BS6853 CSIR 24580f
London Underground Approval	BS EN 62444 LU 3043
EMC Compatible	EN 55011, + A1, EN 55022 SGS EMC305079/1

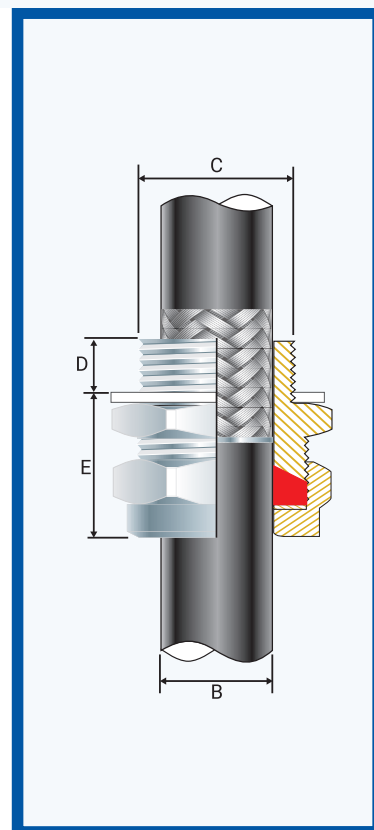

#### Installation Standards

- AS/NZS 3000
- BS 6121-5
- BS 7671
- BS 7430
- IEC 60364-5-54
- SANS 0142

Product Code	Gland Size Reference	Metric Entry Thread		NPT Entry Thread		Cable Detail		Maximum Length 'E'	Hexagonal Detail		Installation Torque Value Nm
		'C'	Min 'D'	'C'	Min 'D'	Min 'B'	Max 'B'		Max 'Flats'	Max 'Crns'	
055200-16SEM	00-16S	M16x1.5	10	-	-	1.0	6.0	20.0	♦ 18.0	♦ 20.0	20.0
055200-16EMC	00-16ss	M16x1.5	10	-	-	3.0	8.5	20.0	♦ 24.0	♦ 27.0	32.5
055200-EMC	00-20ss	M20x1.5	10	½/¾	15	3.0	8.5	20.0	♦ 24.0	♦ 27.0	32.5
0552-0-EMC	0-20s	M20x1.5	10	½/¾	15	7.0	11.5	20.0	♦ 24.0	♦ 27.0	32.5
055201-EMC	1-20	M20x1.5	10	½/¾	15	11.0	15.0	24.0	27.0	30.0	32.5
055222-EMC	2s-25s	M25x1.5	10	¾/1	15/19	11.5	17.5	25.0	35.0	39.0	47.5
055202-EMC	2-25	M25x1.5	10	¾/1	15/19	15.0	20.0	25.0	35.0	39.0	47.5
055233-EMC	3s-32s	M32x1.5	10	1/1¼	19	16.0	22.0	30.0	42.0	47.0	55.0
055203-EMC	3-32	M32x1.5	10	1/1¼	19	20.0	26.5	30.0	42.0	47.0	55.0
055244-EMC	4s-40s	M40x1.5	15	1¼/1½	19/21	22.0	31.5	30.0	52.0	59.0	65.0
055204-EMC	4-40	M40x1.5	15	1¼/1½	19/21	26.0	34.0	30.0	52.0	59.0	65.0
055255-EMC	5s-50s	M50x1.5	15	1½	21	29.0	38.0	42.0	65.0	73.0	82.5
055205-EMC	5-50	M50x1.5	15	2	21	34.0	44.5	42.0	65.0	73.0	82.5
055266-EMC	6s-63s	M63x1.5	15	2	21	38.0	50.0	48.0	80.0	90.0	97.5
055206-EMC	6-63	M63x1.5	15	2½	30	44.5	56.5	48.0	80.0	90.0	97.5
055277-EMC	7s-75s	M75x1.5	15	2½	30	50.0	62.0	50.0	96.0	102.0	115.0
055207-EMC	7-75	M75x1.5	15	3	32	56.0	67.5	50.0	96.0	102.0	115.0
055288-EMC	8s-80s	M80x2.0	20	3	32	54.0	69.0	55.0	96.0	102.0	120.0
055208-EMC	8-80	M80x2.0	20	3	32	65.0	74.0	55.0	96.0	102.0	120.0
055299-EMC	9s-90s	M90x2.0	20	3	32	60.0	75.0	60.0	111.0	125.0	120.0
055209-EMC	9-90	M90x2.0	20	3½	33	73.0	81.5	60.0	111.0	125.0	120.0
055210-EMC	10-100	M100x2.0	20	3½/4	33/34	81.0	91.0	74.0	-	-	120.0
055211-EMC	11-110	M110x2.0	20	4	34	91.0	101.0	92.5	-	-	175.0
055212-EMC	12-120	M120x2.0	20	-	-	101.0	109.0	92.5	-	-	175.0
055213-EMC	13-130	M130x2.0	20	-	-	109.0	119.0	92.5	-	-	175.0

All dimensions except NPT are in mm.  
♦ When manufactured in Aluminium, Hex will be 27 Across Flats and 30 Across Corners.

# A2 LSOH EMC COMPRESSION GLAND

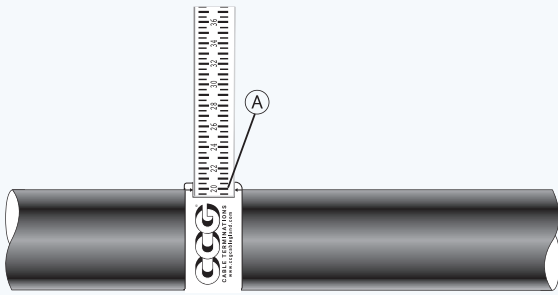

1. For accurate sizing, use a CCG Dimension Tape (A) on the outer cable sheath.

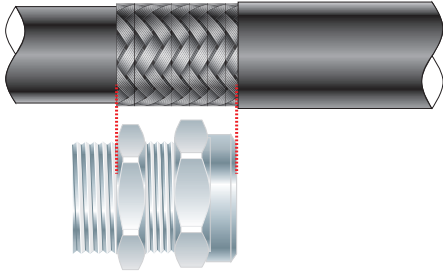

1. Cut back the cable outer sheath to expose the braid to a length not less than the gland assembly.

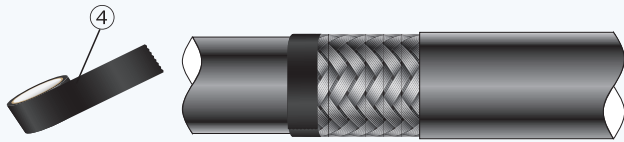

2. Using insulation tape (4), tape the braid on the inner sheath of the cable.

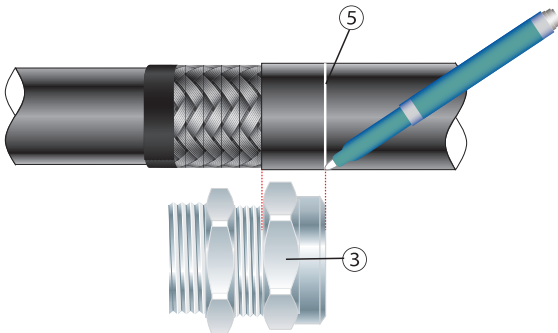

3. Measure the outer nut (3) on the outer sheath and mark (5) the outer sheath.

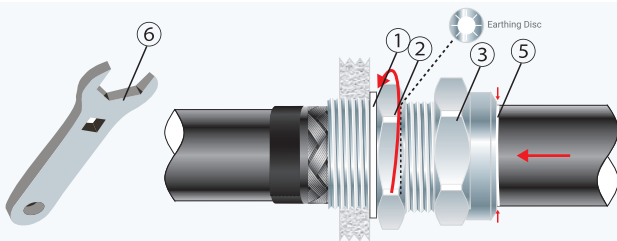

4. To maintain IP66/68, ensure the gasket (1) is in place. Screw the gland assembly into the apparatus. Pass the cable through the gland until the mark (5) on the outer sheath aligns with the outer nut (3) and braid passes through the earth disk. Tighten the inner (2) to the installation torque using a CCG Spanner (6).

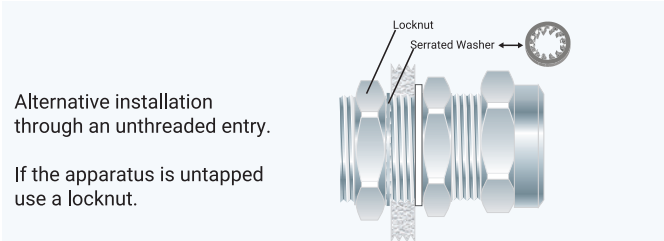

Alternative installation through an unthreaded entry.

If the apparatus is untapped use a locknut.

If the gland has NPT entry threads fitted to a threaded entry then IP68 (2m) can be achieved by applying one of the following tested and approved grease types to the thread:- Renolit Lubrene CA700 or LX220 EP2, Renolit LC-WP2 or Moly LX2, or Dow Corning 4 Electrical Insulating Compound.

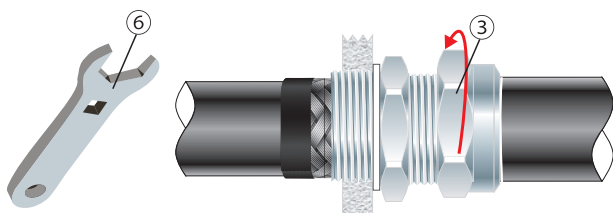

5. Tighten the outer (3) to the installation torque using a CCG Spanner (6).