

A2-FHC

COMPRESSION GLAND

for Unarmoured Cable Housed In Conduit



Features and Benefits

- For indoor and outdoor use.
- For use with all types of unarmoured cable housed in rigid or flexible conduit.
- Tapered seal grips the cable giving superior cable retention and IP rating.
- Fitted with a rotating female conduit coupler.
- Factory fitted with a specially formulated elastomeric seal for Built-in Safety™, seals on the inner sheath of the cable.
- Precision manufactured from high-quality brass (nickel plated), available in aluminium or stainless steel 316/316L on request.
- Complete with a thread-sealing gasket.



Technical Data

Type:	A2-FHC
Gland Material:	Brass (Nickel Plated) BS 2874, EN 12164, Aluminium ASTM BS221, Stainless Steel 316/316L
Seal Material:	Thermoset Elastomer or Silicon on request.
Cable Type:	Unarmoured Housed in Conduit
Sealing Area:	Outer Sheath
Optional Accessories:	Adaptor, Reducer, Earth Tag, Locknut, Serrated Washer and Shroud

Standards and Certifications

Mechanical Properties:	Impact Category 8 Anchorage Type B
Continuous Operating Temp:	-65°C to +120°C
Conformance:	Standard: Certificate:
Design Standards	BS 6121:Part 1 CML 14CA364 EN 50262 CML 14CA364 IEC/BS EN 62444 CML 14CA364 SANS 62444 MASC 22-9012 SANS 1213 MASC 26-9013, SANS 2109/4596
IP66/68 100m - Parallel	IEC 60529 CML 15Y728, MASC 22-9015
IP65 - Tapered	IEC 60529
Marine ABS	IEC 60529, IEC 62444 25-0167207-PDA
DNV	IEC 60529, BS 6121, IEC 62444 TAE000000Z
London Underground Approval	BS EN 62444 LU 3043

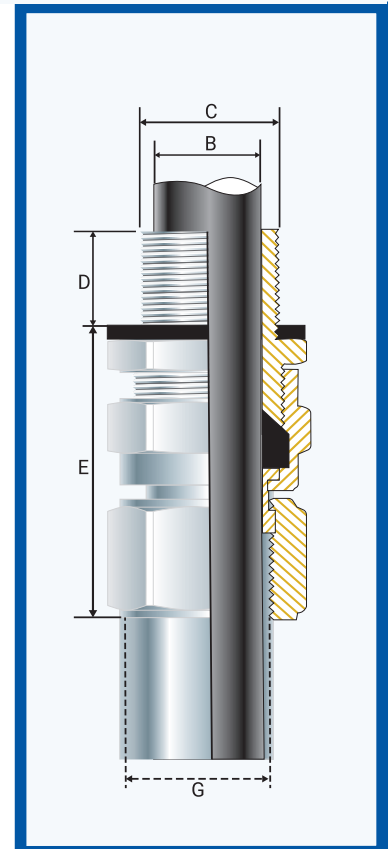

Installation Standards

- AS/NZS 3000
- BS 7430
- BS 6121-5
- IEC 60364-5-54
- BS 7671
- SANS 0142

Product Code	Gland Size Reference	Metric Entry Thread		NPT Entry Thread		Cable Detail		Maximum Length 'E'	Female Conduit Thread		Hexagonal Detail		Installation Torque Value Nm
		'C'	Min 'D'	'C'	Min 'D'	Min 'B'	Max 'B'		Metric 'G'	NPT 'G'	Max 'Flats'	Max 'Crns'	
059200-16S	00s-16S	M16x1.5	10	-	-	1.0	6.0	47.0	M16-M25	-	24.0	27.0	32.5
059200-16	00s-16ss	M16x1.5	10	-	-	3.0	8.5	47.0	M16-M25	-	♦ 24.0	♦ 27.0	32.5
059200	00s-20ss	M20x1.5	10	1/2/3/4	15	3.0	8.5	47.0	M16-M25	1/2/3/4	♦ 24.0	♦ 27.0	32.5
0592-0	0s-20s	M20x1.5	10	1/2/3/4	15	7.0	11.5	47.0	M16-M25	1/2/3/4	♦ 24.0	♦ 27.0	32.5
059201	1-20	M20x1.5	10	1/2/3/4	15	11.0	15.0	47.0	M16-M25	1/2/3/4	27.0	30.0	32.5
059222	2s-25s	M25x1.5	10	3/4/1	15/19	11.5	17.5	52.0	M25	3/4/1	35.0	39.0	47.5
059202	2-25	M25x1.5	10	3/4/1	15/19	15.0	20.0	52.0	M25	3/4/1	35.0	39.0	47.5
059233	3s-32s	M32x1.5	10	1/1 1/4	19	16.0	22.0	53.0	M32	1/1 1/4	42.0	47.0	55.0
059203	3-32	M32x1.5	10	1/1 1/4	19	20.0	26.5	53.0	M32	1/1 1/4	42.0	47.0	55.0
059244	4s-40s	M40x1.5	15	1 1/4/1 1/2	19/21	22.0	31.5	62.0	M40	1 1/4/1 1/2	52.0	59.0	65.0
059204	4-40	M40x1.5	15	1 1/4/1 1/2	19/21	26.0	34.0	62.0	M40	1 1/4/1 1/2	52.0	59.0	65.0
059255	5s-50s	M50x1.5	15	1 1/2/2	21	29.0	38.0	74.0	M50	1 1/2/2	65.0	73.0	82.5
059205	5-50	M50x1.5	15	1 1/2/2	21	34.0	44.5	74.0	M50	1 1/2/2	65.0	73.0	82.5
059266	6s-63s	M63x1.5	15	2/2 1/2	21/30	38.0	50.0	80.0	M63	2/2 1/2	80.0	90.0	97.5
059206	6-63	M63x1.5	15	2/2 1/2	21/30	44.5	56.5	80.0	M63	2/2 1/2	80.0	90.0	97.5
059277	7s-75s	M75x1.5	15	2 1/2/3	30/32	50.0	62.0	82.0	M75	2 1/2/3	96.0	102.0	115.5
059207	7-75	M75x1.5	15	2 1/2/3	30/32	56.0	67.5	82.0	M75	2 1/2/3	96.0	102.0	115.5
059288	8s-80s	M80x2.0	20	3	32	54.0	69.0	90.0	M80	3	96.0	102.0	120.0
059208	8-80	M80x2.0	20	3	32	65.0	74.0	90.0	M80	3	96.0	102.0	120.0
059299	9s-90s	M90x2.0	20	3/3 1/2	32/33	60.0	75.0	92.0	M90	3/3 1/2	111.0	125.0	120.0
059209	9-90	M90x2.0	20	3/3 1/2	32/33	73.0	81.5	92.0	M90	3/3 1/2	111.0	125.0	120.0
059210	10-100	M100x2.0	20	3 1/2/4	33/34	81.0	91.0	95.0	M100	3/3 1/2/4	-	-	120.0

All dimensions except NPT are in mm. All dimensions except NPT are in mm. Male Entry Thread 'C' and Female Entry Thread 'B' can only be any combination of either NPT or Metric threads. Intermediate thread sizes are available on request.

♦ When manufactured in Aluminium, Hex will be 27 Across Flats and 30 Across Corners.

A2-FHC COMPRESSION GLAND

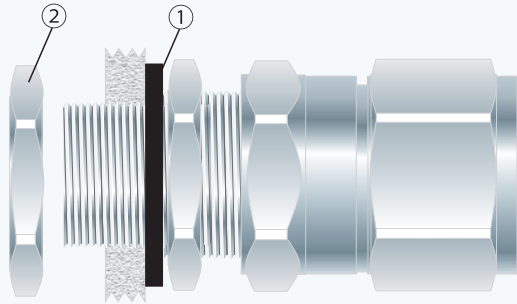

1. To maintain IP66/68, ensure the gasket ① is in place. Remove the locknut ②.

Alternative installation through an unthreaded entry.

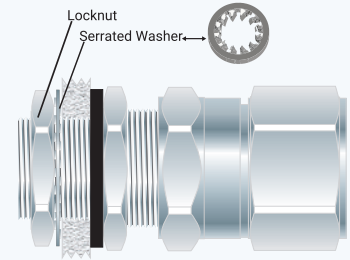

If the apparatus is untapped use a locknut.

If the gland has NPT entry threads fitted to a threaded entry then IP68 (2m) can be achieved by applying one of the following tested and approved grease types to the thread:- Renolit Lubrene CA700 or LX220 EP2, Renolit LC-WP2 or Moly LX2, or Dow Corning 4 Electrical Compound.

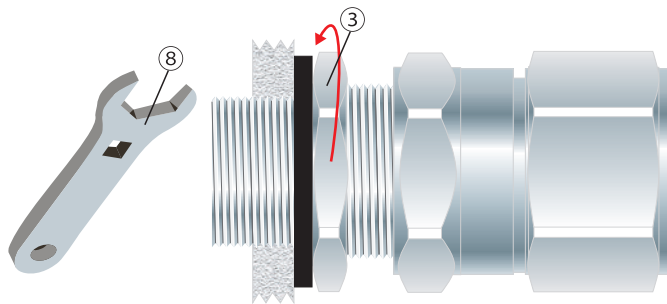

2. Screw the gland unit into the apparatus. Tighten the inner ③ until hand tight using a CCG Spanner ⑧ with ¼ turn.

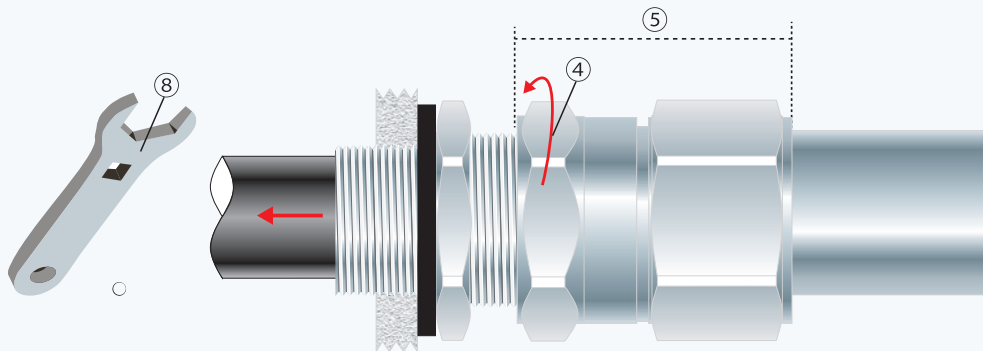

3. Pass the cable end through the conduit assembly ⑤ and the gland assembly. Tighten the outer ④ to the installation torque using a CCG Spanner ⑧ to produce a seal and grip on the cable.

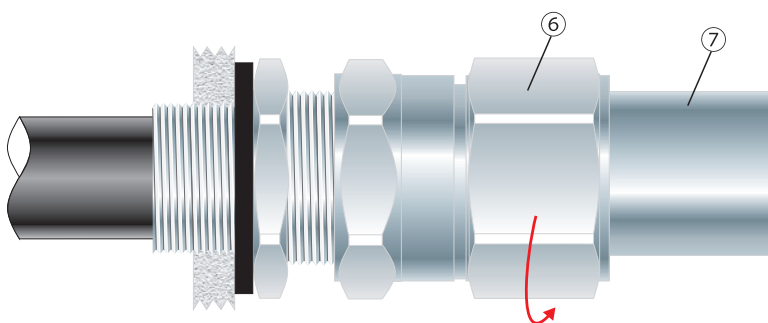

4. Fit the threaded conduit end ⑦ into the female rotating threads ⑥ as indicated.