

SCREW FIT®

3-WAY BOTTOM ENTRY JUNCTION BOX - IP66/68

for General Industrial and Mining Electrical Installations

Features and Benefits

- Screw Fit® 3-Way Bottom Entry Box for general industrial and mining electrical installations.
- A 20mm Box supplied complete with safety securing lid lanyard.
- Raised domed lid facilitates connections to be made outside of the box.
- Only approved CCG cable glands and terminals must be used.
- No exposed metal parts.
- Dust and waterproof to IP66/68, when used with CCG sealed cable glands.
- No drilling or tapping of cable entries is required.
- Mounting studs are provided for DIN rail if using Terminal Blocks.
- Internal earthing to all entries and rail provided.
- The Screw Fit® 3-Way Bottom Entry Box can be buried for extended periods.
- Red Fire-rated Box for emergency circuits is available (925°C for 3 hours).

Technical Data

Type:	Screw Fit® 3-Way Bottom Entry Box	
Box Material:	Impact corrosion and UV resistant glass reinforced polyester compound	
Seal Material:	Nitrile Rubber	
Inserts:	Brass internal earthing and rail mountings	
Optional Accessories:	Certified Terminals, 3-Blanking Plugs and Box Spanner (Lid Locking Key)	

Standards and Certifications

Service Temperature:	-60°C to +110°C (Unfinished)	
Conformance:	Standard:	Certificate:
IEC/BS/EN	62208:2011	CML 17Y11251
SANS	62208:2012	MASC 16-1787
Impact Protection IK10	IEC/BS/EN 62262	CML 17Y11251
IP66/68 Protection	IEC/BS/EN 60529	CML 17Y11251
	SANS 60529	MASC 16-1787
Deluge Protection	DTS 01	CML 14CA370-1
Marine ABS	IEC 60529	25-0167226-PDA
Short Circuit Protection	IEC 60947-7-2, IEC 62444	CATAPULT OR/15/11677_2
Continuous Current Protection	IEC 60947-7-2	CATAPULT OR/15/11677_2
UV Protection	ISO 4892-2	
Zero Halogen	BS7211, BS 50267-2-1	TDW69-09-14
Flammability	UL94V-0	
London Underground Approval	IEC 62208, IEC 62262	LU 3057

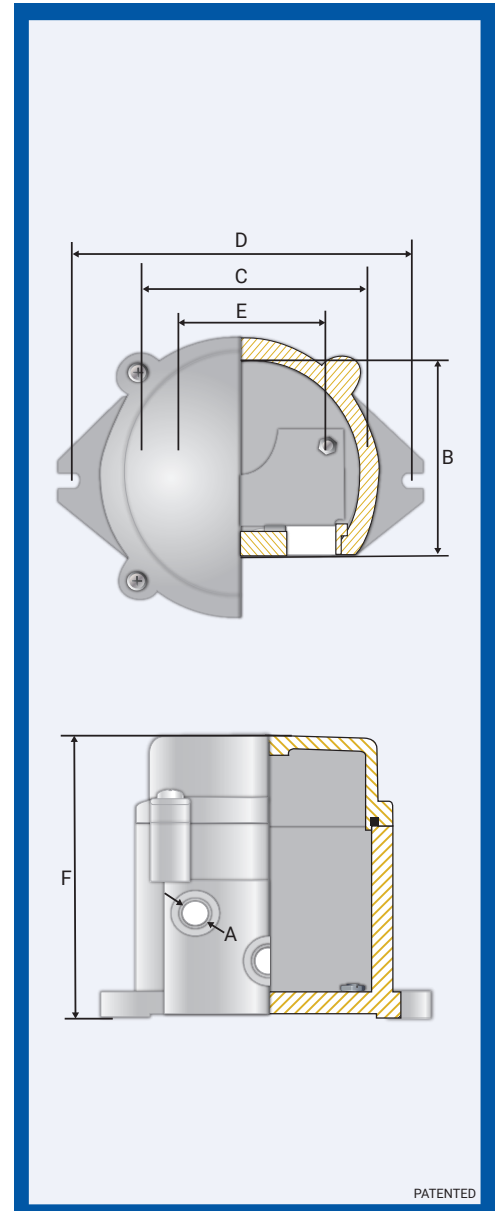
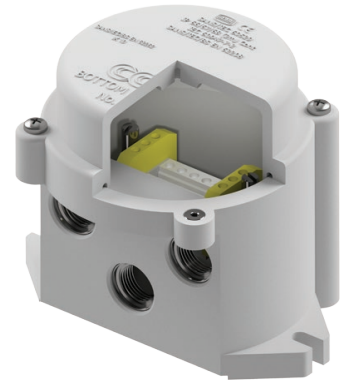

Conditions for safe use

- Only the terminal blocks as per the description may be utilised in the junction box. Specific installation conditions as set by the terminal manufacturer or terminal certification must be considered. This includes considering the use of the applicable partitions and end plates for terminal blocks, conductor installation, tightening down of terminal block screws, etc.
- Terminal blocks may only be utilized on the applicable rail and must allow sufficient space to make connections and to close the cover or lid.
- IP66/68 glands or plugs must be used in the threaded entries.
- Information in relation to entries is indicated in the instructions.

Product Code	Box Size Reference	Entry Thread 'A'	Internal Dimension 'B'	Internal Diameter 'C'	Mounting Centres 'D'	Rail Mounting Centres 'E'	Outer Height 'F'
100201-SF	1	M20 x 1.5	68.0	101.0	132.0	80.0	124.0

All dimensions are in mm.

SCREW FIT® 3-WAY BOTTOM ENTRY JUNCTION BOX

Wiring and installation instructions for Screw Fit® 3-Way Bottom Entry Box with components

- Installation must be carried out by a competent person.
- Do not install under live current conditions.
- The box must not be modified in any way, as this may compromise the integrity of the box.
- All wiring must be carried out in accordance with the relevant Codes of Practice.
- The wiring insulation must not extend by more than 1.0mm from the metal face of the terminal as shown in Figure 1.
- The voltage and current value of the terminals in Table 2 must not be exceeded.
- Only those terminals shown in the terminal schedule may be incorporated in the box; refer to Table 1.
- The inner cable bedding must protrude into the box by a minimum of 20mm past the cable entry point.
- Not more than one single or multiple-strand lead shall be connected to either side of the terminals.
- Only earth conductors of equal size shall be connected with rail-mounted terminals.
- All terminal screws, used and unused, shall be tightened.
- A parallel shaft screwdriver of the correct size should be used for rail-mounted terminal screws.
- Where cables enter the box, they must be secured by CCG Cable Glands appropriate to the makeup of the cable.
- Unused entry apertures must be blanked with CCG standard Blanking Plugs.
- To maintain IP66/68 a thread seal gasket between the box and cable gland must be installed.
- Before replacing the lid, ensure the lid gasket is in place.

TABLE 1

Box Type	Box Size	Terminal Type and Size	Max Quantity	Rail Size
Screw Fit® 3-Way Bottom Entry	1	4mm ² mini terminal	8	15
Screw Fit® 3-Way Bottom Entry	2	2.5mm ²	12	35
Screw Fit® 3-Way Bottom Entry	2	4mm ²	10	35
Screw Fit® 3-Way Bottom Entry	2	4mm ² mini terminal	12	15
Screw Fit® 3-Way Bottom Entry	2	6mm ²	8	35
Screw Fit® 3-Way Bottom Entry	2	10mm ²	7	35
Screw Fit® 3-Way Bottom Entry	2	16 mm ²	6	35
Screw Fit® 3-Way Bottom Entry	2	35mm ²	3	35

TABLE 2

VOLTAGE PER TERMINAL CONFIGURATION

Terminals	Volt	Earth Terminals
AKZ 4	275V	AKE 4
WDU 2.5	550V	WPE 2.5
WDU 4	550V	WPE 4
WDU 6	550V	WPE 6
WDU 10	550V	WPE 10
WDU 16	550V	WPE 16
WDU 35	550V	WPE 35
WDU 70 N	550V	WPE 70 N

Tools /Accessories for general, industrial and mining electrical installations

Pole Mounting Bracket

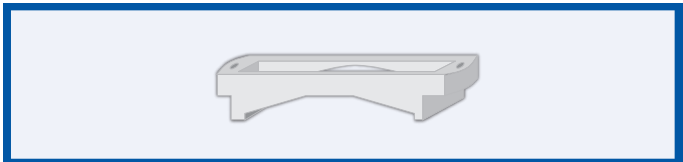

Product Code	Box Size Reference
401800	M20
401801	M20
401802	M25

Non Metallic Plugs IP66/68 complete with washer

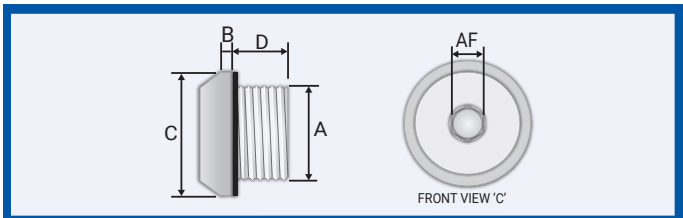

Product Code	Metric Dia 'A'	Dia Max 'B'	Dia Max 'C'	Dia Min 'D'	Hex Size Max A/F	Torque Value Nm
352820	M20x1.5	5.0	28.0	12.0	10.0	7.0
352825	M25x1.5	5.0	33.0	15.0	10.0	9.0



TS 15 Mini Rail

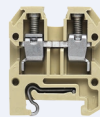

Mini Terminals for conductor sizes 0.5 to 4mm²

FIGURE 1

The wiring insulation must not extend by more than 1.0mm from the metal face of the terminal, as shown below.

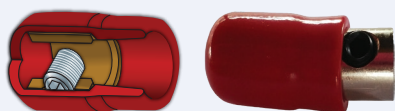
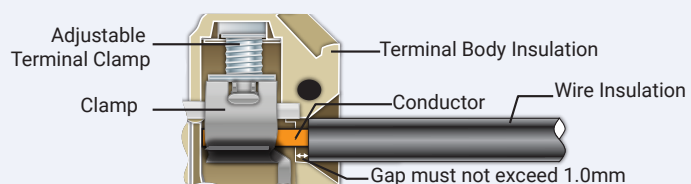

Insulated Terminal Connector 0.5mm to 16mm